

Product Dimension

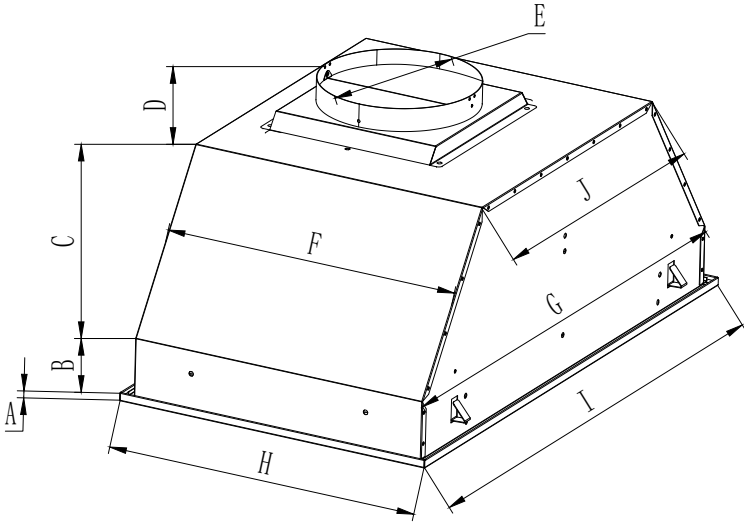

Model	VRH-VANCOUVER-30SS	VRH-VANCOUVER-36SS
A	3/8"	3/8"
B	2 5/8"	2 5/8"
C	8"	8"
D	3 5/8"	3 5/8"
E	6 1/8"	6 1/8"
F	15 1/2"	15 1/2"
G	27 1/2"	33 1/2"
H	16 1/2"	16 1/2"
I	28 1/2"	34 1/2"
J	16 1/2"	17 1/2"

Specifications

Body	Stainless Steel
Power Rating	120V/60Hz(USA &Canada standard)
General Input Power	250W+1 of Light x Voltage of Light
Motor Input Power	250 W
Motor Revolution	600 RPM($\pm 10\%$)to 1300 RPM ($\pm 10\%$)
Levels Of Speed Control	3
Maximum Airflow	900 CFM
Air Pressure	150 Pa(200 Pa Maximum)
Noise Level (dB /sone)	Approximately 35/0.7 to 67 / 6.5(Lowest to highest Speed)
Motor Type	Double Chamber Ultra Quiet
Fan Type	Centrifugal /Sirocco
Control Type	Mechanical Push Button
Filtration Type	Baffle Filter
Illumination	LED 5W
Venting Size	Top 8 inches Round
Interference Protection	Radio Frequency Interference Protected

.Subject to change without notice,please contact your local reseller for details.